

# Driver Alerting System Using CAN Protocol

Venkatesh H<sup>1</sup>, Rajashri Y Manakwad<sup>2</sup>

<sup>1</sup>M.Tech Scholar, Department of TE, Siddaganga Institute of Technology, Tumkur

<sup>2</sup>Assistant professor, Department of TE, Siddaganga Institute of Technology, Tumkur

---

**Abstract:** New paradigm describes about the sufficient benefits of electronic control systems over traditional systems with network architecture on a central processor and it describes about preventing the accidents that are caused by driver errors, to implement it a suitable standardized protocol, CAN, is briefly explained. A major task is to find a way to make it possible to use standardized network modules from different distributors in a network specially designed for a specific vehicle or for an implementing platform. A solution to this problem is to designing a formal set of rules of "CAN Environment" and the basics for this are presented. This alerting system consists of the coordinating and display of data which are not dependent of each other and remotely executed. The data collection module receives data through CAN wire, and the data display module GLCD display these data via GUI designed by Embedded in ARM7 processor. Temperature sensor and different IR based sensors are used as data collection faculty and GLCD, motor and buzzer is used as output faculty. The CAN protocol is briefly presented and its current and future scopes in automobile industries are discussed.

**Keywords:** CAN-Controlled Area Network, GUI-Graphic user interface, GLCD-Graphical Liquid crystal display.

---

## I. INTRODUCTION

The automation is must needed in all systems which increases the overall system performance. Vehicle system [1, 2] is composed of automotive electrical architectures consist of a more number of electronic control units brings out a variety of controlling functions. In vehicle system preliminary basic need is to be greater safety, convenience, and pollution control and fuel consumption should be less. A modern vehicle has many electronic control units (ECU) for various subsystems. Different such subsystems are airbags, antilock braking system, air conditioner control, windows, audio sound systems, mirror adjustment etc. Some of these subsystems form independent or dependent subsystems. Communications between dependent sub systems are more essential.

The key idea is to alert the driver when the driver in unconscious while driving or unaware about driving They are often caused by driver errors such as taking a curve too fast, driving too fast, fatigue, inexperience, or improperly distributing the vehicle's load. So to overcome from this problem we are using some IR based sensors to implement in real time applications.

Traditional electronic control system can improve a vehicle dynamics, economy and comfort. But some problems also have come up, such as the increased body wiring complexity, space constraints and some reliability issues. In order to overcome from these problems, the intra-vehicle network technology has been created. In-vehicle networking protocols must satisfy requirements which include, significant reduces the harness of wiring, reducing body weight and less costs, improving the efficiency of fault detection, low latency times and high flexibility and enhancing the level of intelligent control. Sub-systems require the exchange of particular performance and position information within defined communication latency. Therefore the requirement for each ECU [3, 4] is to communicate via some kind of network technology such as CAN (Controller Area Network) bus or wire. In the proposed work CAN bus protocol is extensively used for vehicle automation

CAN protocol helps to transmit the data up to 1Mbps speed and implements fixed priority scheduling of CAN messages to avoid collision. Higher priority node which has lower node ID If available bandwidth is limited; problems come with scheduled fixed-priority policy. It has [5] possibility that low priority control loops cannot access the main network all the time, since scarce resources have been consumed by higher priority loops. As a result large number of delays arises, low priority control loops may be destabilized to overcome from the packet loss problems and delays must be controlled.

## II. PREVIOUS WORK

The CAN bus are used in vehicles to make connection to the engine control unit and transmission of information, to connect the door locks of vehicle, air conditioner control etc. Today the CAN bus is majorly also used as a connection bus

in general automation environments, primarily due to the cost effectiveness of some CAN controllers and processors. Robert Bosch holds patents on the technology, and manufacturers of CAN-related and compatible microprocessors pay license fees to Robert Bosch, which is normally moved on to the customer in the price of the chip. Manufacturers of products with custom ARM processors containing CAN-compatible modules must pay the certain amount for the CAN Protocol License.[1, 3, 7] But nowadays CAN protocol based applications drastically increased which leads to easy upgradable capacity of CAN

### III. CAUSE FOR VEHICLE ACCIDENTS

Errors made by drivers cause most accidents. Impaired drivers (whether by sleep deprivation, alcohol or use of prescription medication) make poor judgments, take unnecessary risks, and are failure to react to the dangers on [8] our roadways. The main reason for accidents are applying front brakes suddenly, driving too fast, the, and improperly among other things.

### IV. BLOCK DIAGRAM

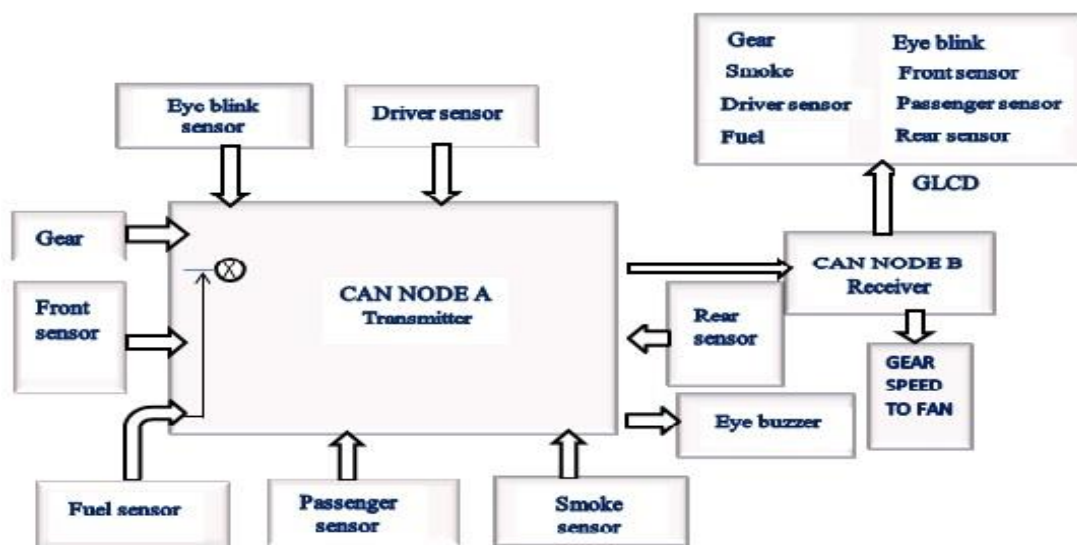

Fig: 1. Block diagram of alerting system

#### A. IMPLEMENTATION PART:

CAN MODULE: We are using two nodes i.e. Transmitter part, Receiver part CAN node is implemented using LPC2129. We are using two channels. CAN second channel is configured for 125 KHz.

#### B. TRANSMITTER PART:

Eye Blink sensor is implemented using external interrupt one i.e. 0.3, Rear sensor is implemented using general purpose I/O T0.16, Driver sensor is implemented using general purpose I/O T0.17, Front sensor is implemented using general purpose I/O T0.18, Passenger sensor is implemented using general purpose I/O T0.19, In Fuel sensor four conditions will be implemented For empty condition implemented using Front sensor is implemented using general purpose I/O T0.10, For 30% fuel level condition implemented using Front sensor is implemented using general purpose I/O T0.11, For 60% fuel level condition implemented using Front sensor is implemented using general purpose I/O T0.12, For 100% fuel level condition implemented using Front sensor is implemented using general purpose I/O T0.10

#### C. JOYSTICK IMPLEMENTATION:

ADC code is used for joystick implementation. ADC value is been transmitted by a transmitter and through a receiver ADC value is been taken and I/O blink operation will be done. Further this I/O will be given to a DC motor and based on ADC value all four gear shifts will be implemented. For ADC we use channel1 to read variations from 1.3V to 1.5V to be neutral position. For gear1, gear2 and gear3 we use 3.1V to 3.3V. For decrementing the gear we use 0V to 0.1V. For ADC we use successive approximation, the frequency which scales down to 4.5MHz. Controller operating frequency is 30MHz. Here we use 10-bit resolution implementation. ADC is scanned during power-on bit. For testing purpose the CAN data packets use to transmit to the hyper- terminal. The data packets are shown below,

Fuel	Rear	Passenger	Driver	Front	Smoke	Eye-blink	Gear	ID
	Sensor	Sensor	Sensor	Sensor	Sensor	Sensor	Info.	

Fig 2 data packets

The CAN frame contains 11-bit identified, which can support up to 8 bytes of data transmission. Here '0' is dominant bit, '1' is recessive bit.

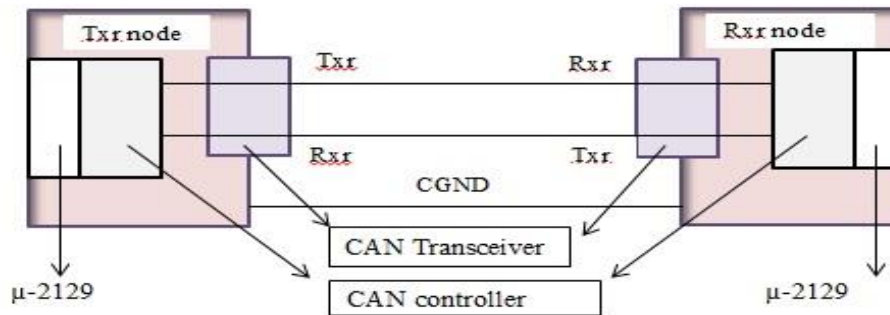

Fig 3 CAN transmitter and receiver

#### D. RECEIVER PART:

To implement receiver part using three modules it is easy to implement and establish the communication between transmitter and receiver of the CAN. They are GLCD, [11, 12] CAN receiver and PWM. Which plays a key role in designing of the system hardware.

#### V. SYSTEM HARDWARE

Basically system hardware refers to hardware components to implement the system to alert the driver that includes GLCD, Joystick, ARM Processor, Eye blink sensor, Fuel indication sensor, Smoke Sensor, Basic IR sensor, Relay, Buzzer, and CAN bus.

- **GLCD:** Graphical LCD has a format for displaying of 128x64 dots and has yellow-green color backlight. Each LCD needs a controller to function as well as to execute its internal operations and to control certain operations. This LCD uses two KS0108 mini controllers. And it used to display the information on the display board.
- **Joystick:** It is used to control the gear system instead of using hard lever hence making use of smart joystick it is easy to implement gear system, Joystick is an toggle switch control, its small in size, momentary contact joystick toggle switch package. It is co-ordinated, basic snap-action switch, and this switch is used in minor applications where it is required to provide ON/OFF control to devices such as motors.
- **ARM Processor:** The ARM7 (LPC2129) is a general purpose 32-bit microprocessor, which offers very high performance and low power consumption. The ARM architecture is mainly based on Reduced Instruction Set Computer (RISC) principles, and the more instruction set and it has simple related decode mechanism than those of micro-programmed Complex Instruction Set Computers (CISC). The main aim of using ARM is it has more instructions set than any other processor this simplicity results in a high instruction throughput and efficient real-time interrupt response from a small and cost-effective processor core.
- **Eye Blink Sensor:** It monitors the driver whether he felt asleep, while driving the vehicle if the driver slept for a while means it will alerts the driver by providing buzzer on. Infrared transmitter it's a type of LED which emits an infrared rays usually called as IR Transmitter. Similarly IR Receiver is mainly used to receive the IR rays transmitted by the IR transmitter. One important thing is it's both IR transmitter and receiver should be placed straight line to each other to meet line of sight principle.
- **Smoke sensor:** It is implemented in the engine as well as fuel container whenever it detects the presence of smoke it will provide the information to the driver to escape from the fire hazard.
- **CAN Bus:** CAN Bus facilitates the major functionalities they are Supports 1 Mbps operation, Implements an standard ISO-11898 [13,14] standard physical layer requirements, it is Suitable for only 12V and 24V systems.

It has Externally controlled slope for a reduced RFI emission, Detection of ground fault on Transmitted input, Power-on reset and voltage breakdown protection, An unpowered node or break down event will not disturb the CAN bus hence it has Low current standby operation.

## VI. ALGORITHM TO IMPLEMENT CAN PROTOCOL

The main algorithm used to [9, 10] implement the driver alerting system using CAN protocol is by making use of KALMAN Algorithm. The algorithm transmission flow is given by

Kalman algorithm design flow is given below

- a) Transmitter Part
  - i. Sensors are connected to ADC.
  - ii. Communication is through CAN1.
- b) Communication is through CAN2.
  - i. After receiving the CAN values, it will display on GLCD.
  - ii. If exceeds certain limit, warnings will be given.
- c) Execution Model
  - i. First select the pins of CAN, ADC and UART channels using PINSEL0 and PINSEL1 registers in LPC2129.
  - ii. Configure 9600 baud rate for serial ports with 8 bit communication mode and 125 Kbps for CAN channel
  - iii. If time is required then we can use internal RTC by setting control registers.
  - iv. ADC in ARM7 can be configured by using ADCR register and data can be converted in to ADDR register.
  - v. Now connect two ultrasonic sensors to the ADC of ARM7 controllers and place them at front and rear ends.
  - vi. Whatever the data is coming from these sensors monitor it and send continuously using CAN1 channel to CAN2 through bus.
  - vii. Based on the data coming to CAN2 channel through the bus, the controller will decide which operation should perform.
  - viii. If any object is very near to the vehicle then the vehicle will be stopped automatically.
  - ix. By using Kalman algorithm we can find out the relative speed between the nearby vehicles and monitor it continuously.
  - x. All these information are displayed on the GLCD.

## VII. RESULTS

In this specified model combination of wired and wireless technology can be achieved by using CAN protocol or CAN bus, In olden days monitoring and controlling of machine or vehicle are done by the manual settings but by using CAN bus in the implementation of vehicle automation it has wider applications with low power consumption and increases the overall system performance and automatically monitors the system by getting the sensed information from all IR based sensors and these information is carried out by CAN bus at the transmitted speed of 1mbps Hence by using CAN efficiency and accuracy of the system can be increased, The main goal of using this system is it can support higher data rate, Now differentiating of data rates of existing and proposed technique is shown in graph1 and by using CAN protocol we the reduce the system model nodes . Graph 2 shows the efficiency of CAN and other protocols.

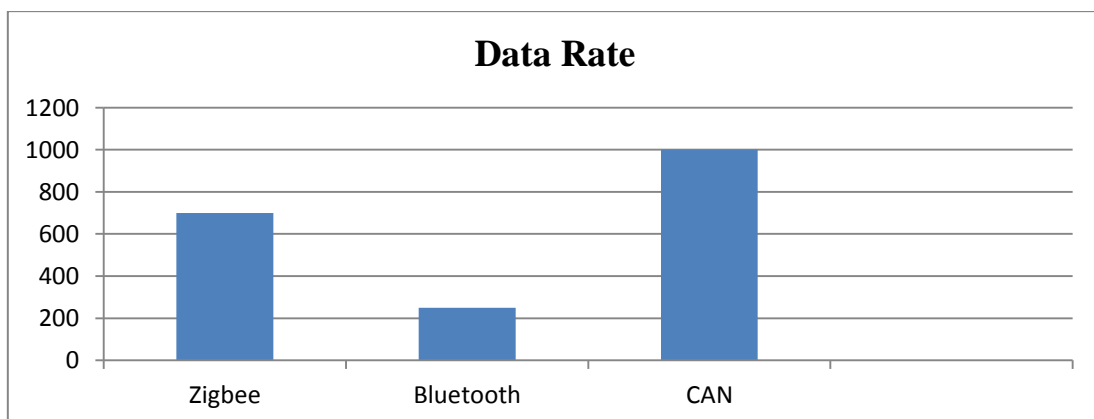

Graph 1 Differentiating of Data rates

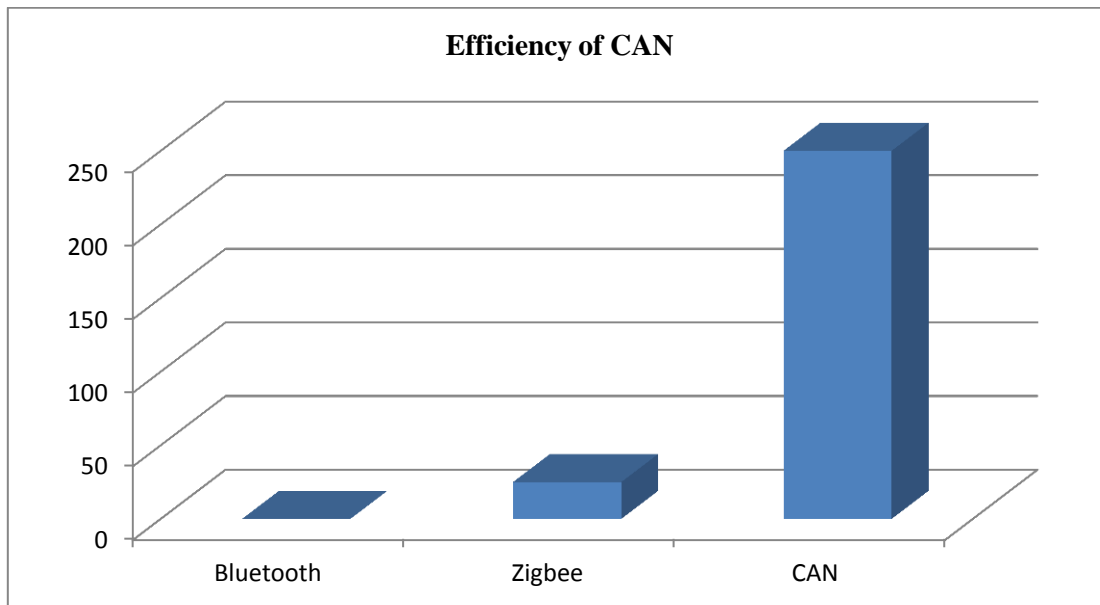

Graph 2 Comparison of Efficiency of CAN and other protocols

## VIII. CONCLUSION

This paper CAN BASED DRIVER ALERTING SYSTEM is intended for secure and smooth journey. The vehicle itself will have aware of its movement. If the driver himself is notable to concentrating on driving or any other parameters, which may cause damage to vehicle as well as his life also, this intelligent vehicle warn the driver regarding the danger ahead. As the value of a human life is countless times more than the cost of this project, we are proud to be behind the success of this project.

Real-time, reliability and flexibility etc. all these characteristics make CAN BUS an indispensable network communication technology applied in automobile network communication field. In this paper, the CAN-bus based communication system for vehicle automation is designed. Software system and hardware system are easily to be expanded and upgraded.

## IX. FUTURE SCOPE AND ENHANCEMENTS

The automobile incorporating a machine-to-machine (M2M) device (GPS/GSM modem with a crash detector), the mobile operator and the emergency organizations Network. Research is still in progress to make a platform for emergency rescue in case of an auto crash and developed a prototype and tested it. Therefore, the platform operates in optimal mode in order to reduce the golden time of arrival when every micro-second counts.

## REFERENCES

- [1] Li Ran, Wang Haying, Li Gechen. "Design Method of CAN Bus Network Communication Structure for Electric Vehicle", IEEE. Published year 2010
- [2] Mingjun Zhang, Yujia Wang, Hao Su "CAN-Bus-Based Communication System Research for Modular underwater Vehicle", published year 2011.
- [3] Chin E. Lin, S. F. Tai, H. T. Lin, T. P. Chen, P. K. Chang, C. C. Kao "Prototype Of A Small Aircraft Avionics Using Hybrid Data Bus Technology" Published year 2010
- [4] Hung-Ming Yen, Chin E. Lin, "A Prototype Dual Can-Bus Avionics System for Small Aircraft Transportation System".
- [5] Ekelin, N. Suri, V. Claesson, C. "The event-triggered and time-triggered medium-access methods", 6th IEEE International Symposium on Object-Oriented Real-Time Distributed computing, May 2003, paper. 131-134.
- [6] Richard McLaughlin, Chris Quigley, "Electronic System Integration for Hybrid and Electric Vehicles".
- [7] Chin E. Lin, H. M. Yen, "Reliability and Stability Survey on Can-Based Avionics Network for Small Aircraft" published on 2005 IEEE.

- [8] Jing Du, Shurui Fan, Hexu Sun, Tao Liang “Research on Mixed Traffic Scheduling of Networked Control Systems Based on CAN Bus” 2009 volume no.64
- [9] Feng Xia, Xiaohua Dai, Zhi Wang, and Youxian Sun, “Feedback Based Network Scheduling of Networked Control Systems” 2005 IEEE.
- [10] Claesson, C. Ekelin, N. Suri, “The event-triggered and time- triggered medium-access methods”, 6th IEEE International Symposium on Object-Oriented Real-Time Distributed computing, May 14-16, 2003, pp.131-134.
- [11] Chris Quigley, Richard McLaughlin, “Electronic System Integration for Hybrid and Electric Vehicles”.
- [12] Chin E. Lin, H. M. Yen, “Reliability and Stability Survey on Can-Based Avionics Network For Small Aircraft” - 7803-9307- 4/05/2005 IEEE.
- [13] Feng Xia, Xiaohua Dai, Zhi Wang, and Youxian Sun, “Feedback Based Network Scheduling of Networked Control Systems” 2005 IEEE.
- [14] Prof. Vidhyadhar B. Dharmadhikari, Ashwini S. Shinde, “Controller Area Network for Vehicle Automation” International Journal of Emerging Technology and ISSN 2250-2459, Volume 2, Issue 2, February 2012.
- [15] Siva Kumar S, A. Sadhiqin M I, Zulkifli Syarif, “Controller Area Network (CAN) Application in Security System” World Academy of Science, Engineering and Technology published on 2009.